

Navigation Light Controller and Control panel

Ships manual

Rev. 7.1
Nov 2023

Control panel

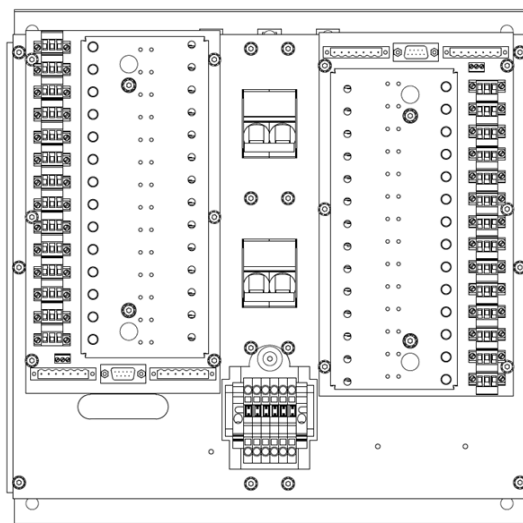
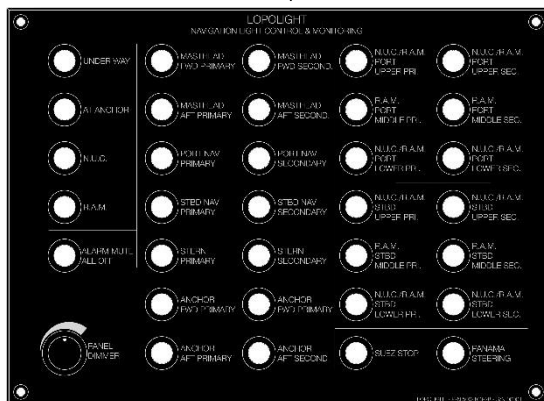

Navigation Light Controller (NLC)

Table of contents:

<u>Section:</u>	<u>Page:</u>	<u>Text:</u>
1.0	3	Preface
1.1	3	Modular principle
1.2	3	Basic working principles
1.3	5	System overview
2.0	6	Standards and resolutions
3.0	6	Navigation Light Controller basic data
3.1	7	Controller power and connections
3.2	8	Navigation Light Controller installation guide
3.3	9	Controller, direct control (emergency operation)
3.4	10	Controller schematics
3.5	12	Controller, service and maintenance
4.0	13	Panel, basic data
4.1	15	Panel installation guidelines
4.2	16	Panels– detailed drawings
5.0	19	Initial installation and set-up
5.1	21	Teach in
5.2	22	Programming the panel
6.0	23	Manuel control
7.0	24	System LMR/Q's
7.1	24	System reset
7.2	24	Setting the address of the LMR/Qs
8.0	26	Test procedure
9.0	27	Using the panel
9.1	28	Spare parts
10.0	29	Troubleshooting guide and instructions
10.1	33	General test of Navigation light function
11.0	33	Exploded Illustration of NLC components
12.0	37	Lopolight contact information

1.0 Preface

The Lopolight Navigation Light Controller (NLC) and Control panel, described in this document, is a simple system to install and operate, that can control several Lopolight navigation lights.

It is delivered without setup, which must be completed as described in sections 5 and 6 before using the system.

The modular-built system offers integrated power-supplies, monitoring and control functions and an elegant control panel. The system satisfies all required demands for a complete NLC installation for all types and classes of ships, meeting and exceeding relevant standards and resolutions.

The system is based on the type-approved Lopolight Monitoring Relay (LMR/Q). Please refer to section 2 for further information concerning approvals.

The 28-button panel is used in examples in this document as the functionality of all three versions (14, 21 and 28) is identical.

1.1 Modular Principle – up to 28 outputs.

The basic NLC controller consists of up to 14 outputs (navigation light connections), and can be extended with 14 additional outputs, totalling 28 controllable outputs. If more than 28 channels/ connections are required, multiple systems can be installed in parallel.

The panel, which is available in three standard versions containing 14, 21 and 28 buttons respectively, is delivered with customer specified texts for each button. Please refer to www.lopolight.com for ordering information.

1.2 Basic working principle

The complete system consists of two basic components;

1: The NLC

The NLC holds the LMR/Q monitoring relays, primary power-supply, secondary (emergency) power-supply, and navigation light connection terminals as well as terminals for connecting a control panel or other remote-control device.

The NLC is normally operated by a control panel (LPL P/N: 500-110) but can also be operated with a customer designed control system using RS-485 data communication.

2: The CONTROL PANEL

The control panel holds 28/21/14 operation buttons, 4 group buttons, an alarm and panel dimming feature.

The control panel and NLC are interconnected via a flexible 7 wire cable which comes with the system if a panel is ordered. The cable connects to the control panel with a SUB D9 connector and in the NLC with either a 7-pin terminal connector or a SUB D9 depending on customer specifications and terminal availability.

Multi-processor principle:

The NLC controller holds several Lopolight Monitoring Relays (LMR's), that are the basic component in the system. One LMR/Q is assigned to each individual output.

Each LMR/Q is assigned a logical address that can be controlled by a data telegram from the controller (panel or similar). The multi LMR/Q processor principle offers the highest possible degree of redundancy as every navigation light is monitored by a separate monitoring relay.

The LMR/Q has the following diagnostic (light on top of card)

- Green constant on: Light on, controller ok, **ok signal to panel**
- Green short flash: Light off, controller ok
- Red constant: Total light failure, controller ok, **alarm to panel**
- Red blinking: Partial light failure, controller ok, **alarm to panel**
- Orange constant: Current limiter active/short circuit, controller ok, **Alarm to panel**

- Orange blinking: Teach-in active, controller ok
- Green blinking: Light expires soon (more than 48.000 operating hrs.)
- Alternating red/green: Light expired (> 50.000 operating hrs.), **alarm to panel**

To prevent shortage of luminous intensity of LEDs: An alarm function is provided to notify the Officer of the Watch that the luminous intensity of the light reduces below the level required by COLREGs, as per MSC 253(83) requirements.

Current limiter:

The LMR/Q has built-in over current protection. This function activates if the current supplied to the navigation light is over 2 Amp. When a short is detected the LMR will immediately cut supply. It will automatically reset after 30 sec. If the short is still present, the procedure will be repeated.

There is also a version that will not reset after 30 sec. It is recognized by a white button on the LMR/Q card, instead on a black button.

1.3 System overview

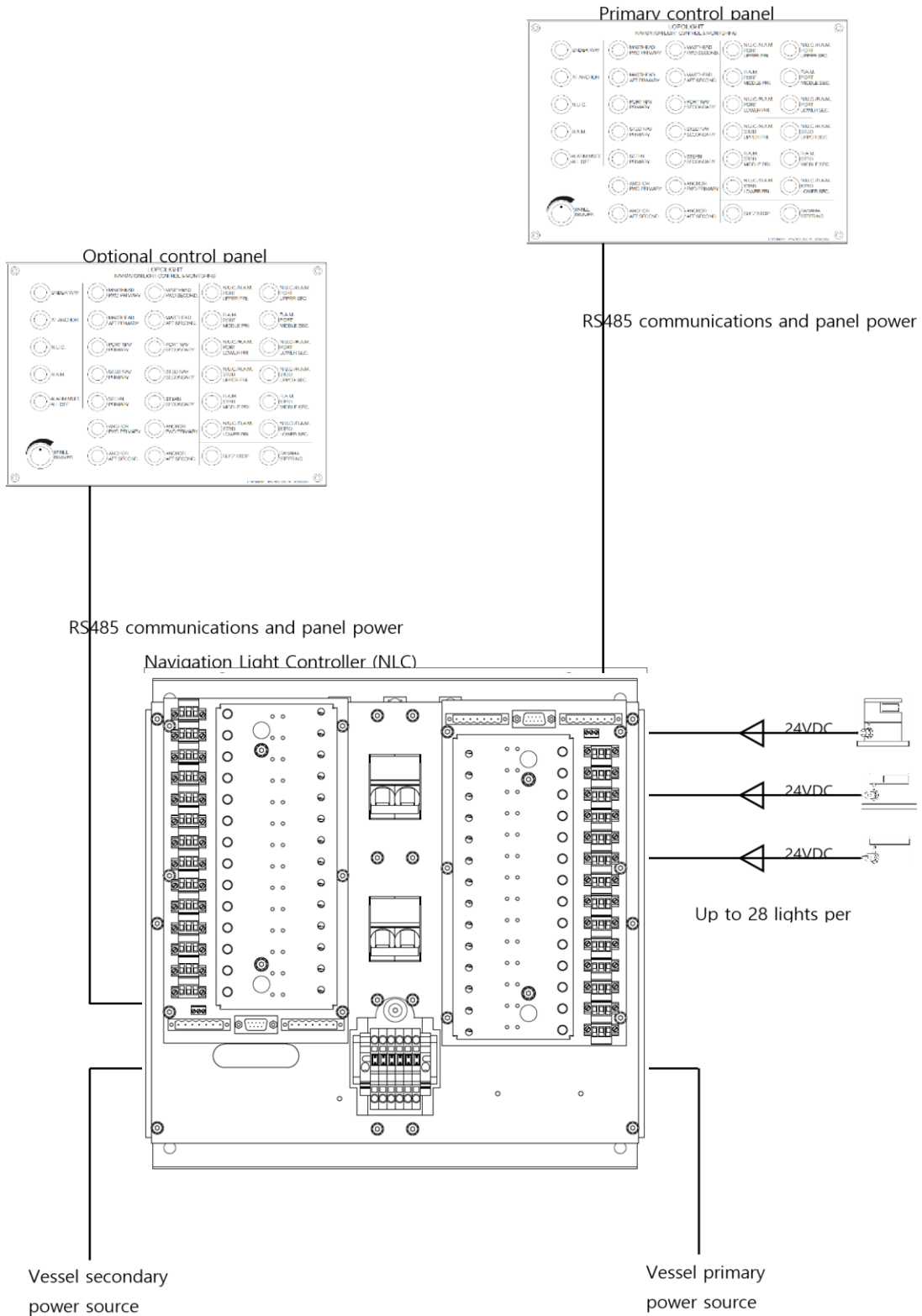

2.0 Standards and resolutions

The system meets and exceeds the following standards, type approvals and resolutions:

ABS approval 20-2067759-PDA

*Refer to “Approvals” under <https://www.lopolight.com/Download/certificates>

3.0 Navigation Light Controller basic data

Installed in cabinet:

Cabinet:	Steel enclosure (Schneider-Electric: Special S3D)
Dimensions (WxHxD):	400*400*200mm
Mounting:	Mounting brackets.
Weight:	13,6 kg. (including a total of 33 pcs M16 blinds/glands)
Ingress protection:	IP66 (depending on selected cable entry system)
Cabinet certificates:	BV, CUL, DNV, GL, LR, UL
Colour:	RAL 7035 (Light grey)

Protective ground connection: M6 bolt connection protruding from cabinet
Theoretical temperature rise: 25°C. above ambient @ 200W load.

Open installation (without cabinet):

Dimensions (WxHxD):	354*350*148.5mm
Mounting:	4 wall screws (not supplied with system)
Weight:	~5 kg. (full version)
Ingress protection:	IP 22 Either install in sealed compartment or in Cabinet to achieve IP rating.

Protective ground connection: M6 bolt connection on base plate
Theoretical temperature rise: 25°C. above ambient @ 200W load.

3.1 Controller power and connections:

Inputs:

Primary power-supply, Option A: 100-240VAC 50/60Hz, Maximum 250W

Primary power-supply, Option B: 19-32VDC, Maximum 250W

Sec. power-supply, Option C: 100-240VAC 50/60Hz, Maximum 250W

Sec. power-supply, Option D: 19-32VDC, Maximum 250W

Internal circuit protection: 100-240 VAC: 6A[C], 19-32 VDC: 10A[C]

Connections: Elevator type screw terminals: 1.5 - 6 mm²

Isolation: Power supplies are galvanic isolated from vessel installations.

The primary and secondary power supplies are independent of each other, a short circuit or power failure on one will not affect the operation of the system, as there is an automated transfer of power to the secondary power supply.

Outputs:

Number of nav. light connections: Up to 28 LMR's based outputs

Max. output voltage: 32VDC

Max. output current: 2 Amp per output. With automatic current limiter

Max. total output: 220W (total max. consumption must be calculated)

HW alarm output: Max. 200 mA open collector (sink)

HW alarm reset: Edge triggered low-going. (apply system minus to reset) Power supply to panel: 24 to 32VDC, max 200 mA via data plug(s)

Data communication:

Physical: RS-485: 38400, N,8,1

Data protocol: Lopolight LMR/Q protocol

Data comm. interface option 1: SUB-D9 (refer to section 3.4)

Data comm. interface option 2: 7-pin screw terminal plug (refer to section 3.4)

Termination resistor: 120Ω in screw terminal. Normally located in NLC.

Control panel:

Lopolight P/N: 500-110-XX may be used to control the outputs. The panel includes status indication and both visual and audible alarm outputs.

Number of control panels: Up to 12 panels may be connected simultaneously to the NLC.

Other control possibilities: The control panel can be controlled by NMEA 0183 via comport 2, on the panel.

3.2 Navigation Light Controller installation guide

Placement:

The controller must be installed in a protected* environment at bridge level and is recommended to be installed on a vertical surface (wall mounted). (*Refer to EN-60945 / IEC-60945 in section 8.2)

Accessibility:

The enclosure door must be reachable, and it must be possible to open it fully in order to gain access to the manual (emergency) control buttons. It must be possible to gain full access to the manual control buttons within 2 minutes.

Temperature:

Ambient temperature range: -15°C to 50°C

NB! Avoid placing the controller near other equipment that creates excessive heat.

Mechanical:

Secure to bulkhead/wall using four pcs. of min. 10mm bolts. Ensure that the bulkhead/wall is suitable of carrying a load of 13 kg – also under heavy vibration.

Power supply:

Ensure that proper cable types and dimensions are used for the powersupply/supplies. Refer to section 3.1 for details (suggested minimum cable dimensions is 2.5 mm²)

Cable entries:

Power, communication and output cables must be strain relieved externally, in accordance with “good workmanship practise” and relevant standards.

Output cable installation – internal:

Connect the individual cables to relevant output plug/terminal using appropriate ferrules to protect the wire strands.

Ensure correct polarity (**L+** = positive, **L-** = negative).

Scr. = screen/protective earth should be connected to cable screen, unless cable screens are ground connected elsewhere near the controller.

Secure plugs with screws before finishing installation.

Recommended cable dimensions: 0.5 to 2.5 mm².

Output cables:

Output cables may be connected directly to the controller. If heavy-duty ships cables are used, it may be necessary to terminate these at an external terminal bar, and then connect the external bar to the output plugs of the controller using cables or wires with a smaller dimension.

If the controller is installed in an enclosure, cables should be drawn from the gland plate (fitted at the bottom of the enclosure) at the underside of the support plate and emerge just before the dedicated connector (K1-14)

Protective ground:

Protective ground must be connected to the cabinets or base plates ground point using proper sized grounding wire or mesh. (suggested minimum: 6 mm²)

Compass safe distance: 0.5 meter (NLC only).

3.3 Controller, direct control (emergency operation)

The individual Monitoring Relay (LMR) outputs can be controlled manually by a simple keypress. The output will toggle between on and off at every key press. The output can be in three states: OK, ALARM and OFF. If an output is off, then the indicator will be off.

If the output is on, the green “ok” indicator will illuminate.

If the connected navigation light is faulty the red alarm indicator will illuminate.

The direct controls are independent from the control panel and are classified as “Manual Emergency Control”

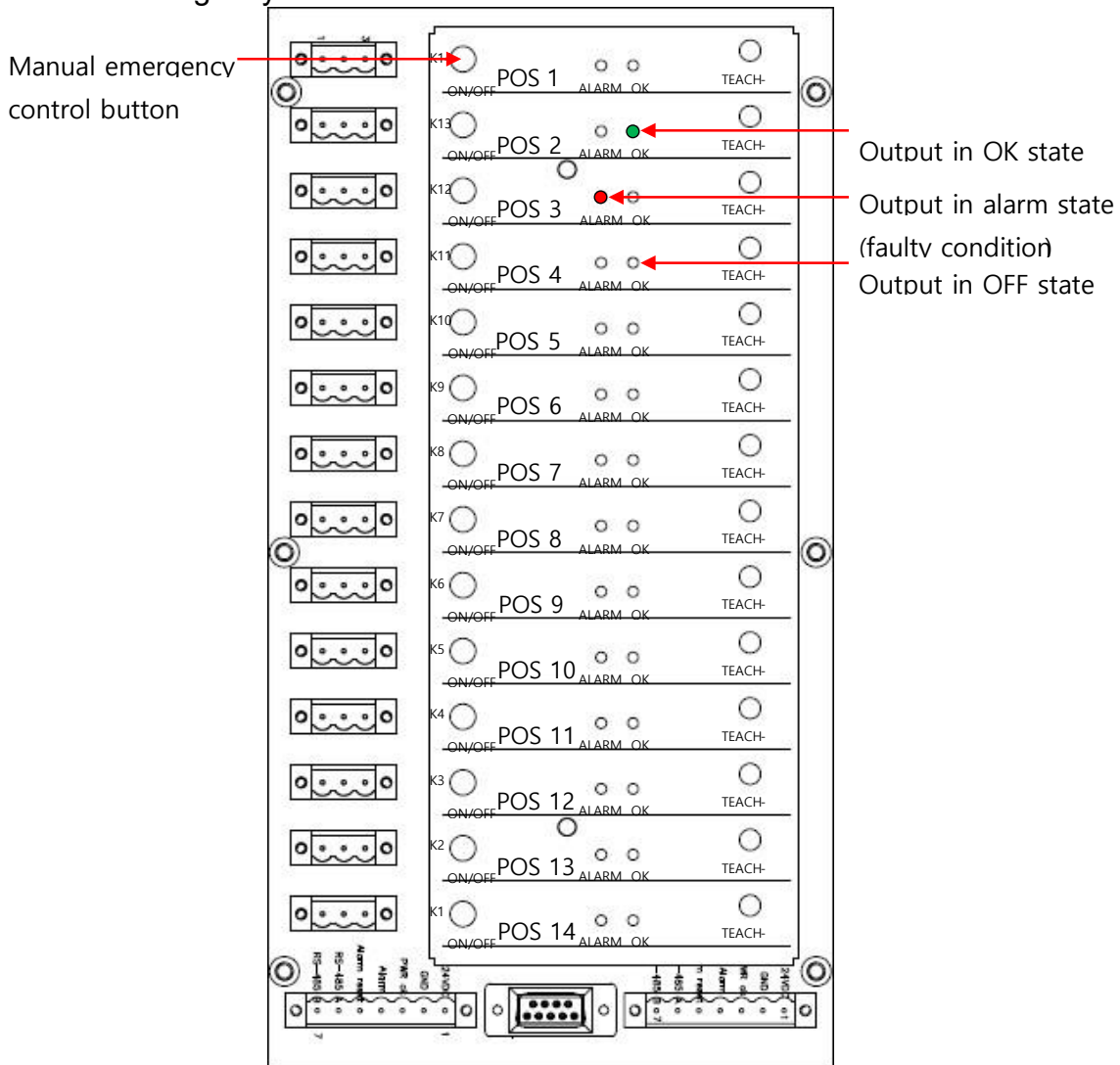

3.4 Controller schematics

Including power-supply and power monitoring function.

Note that the individual systems can have different power supplies as the system is offered with any combination of AC and DC inputs depending on project specifications.

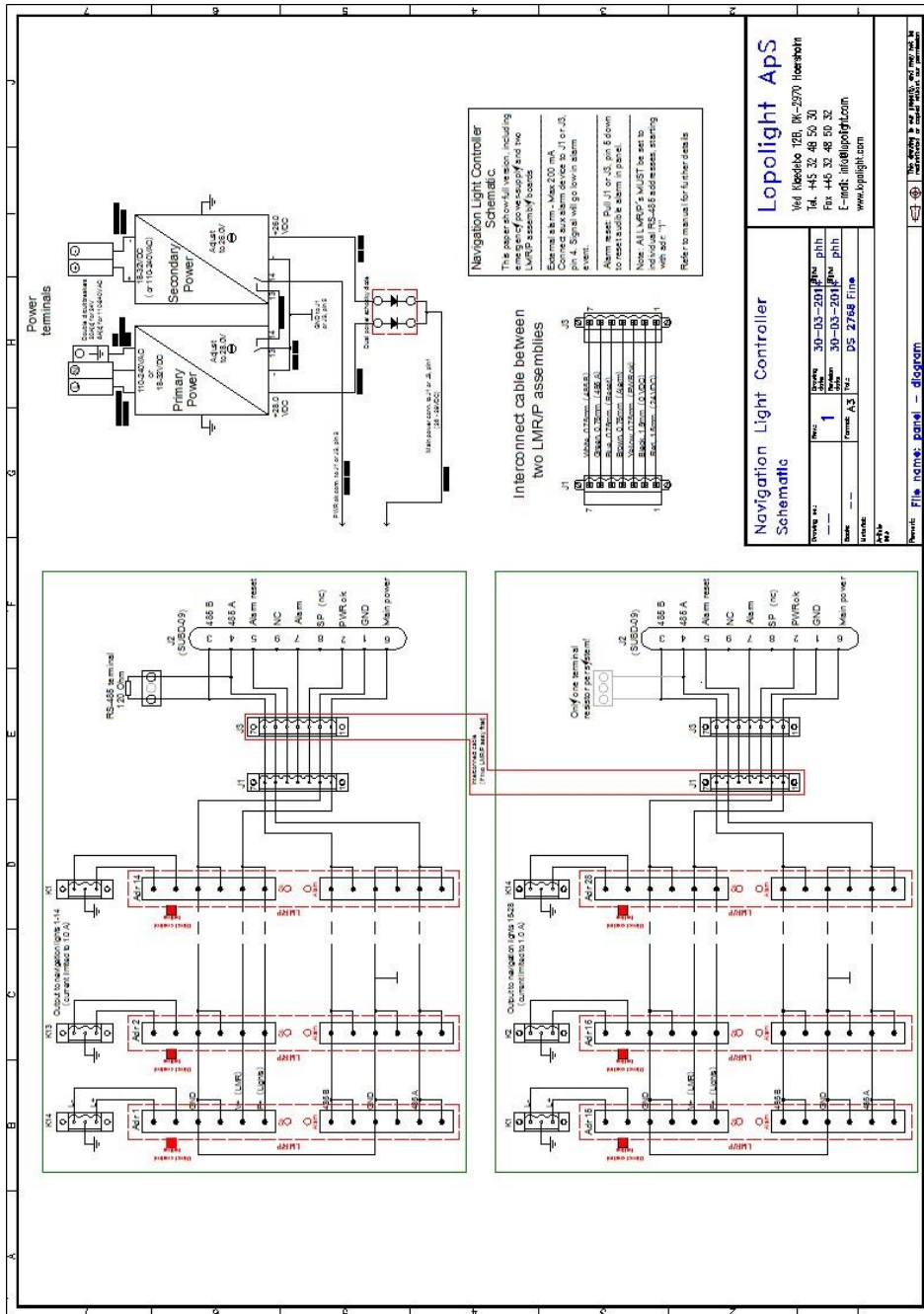

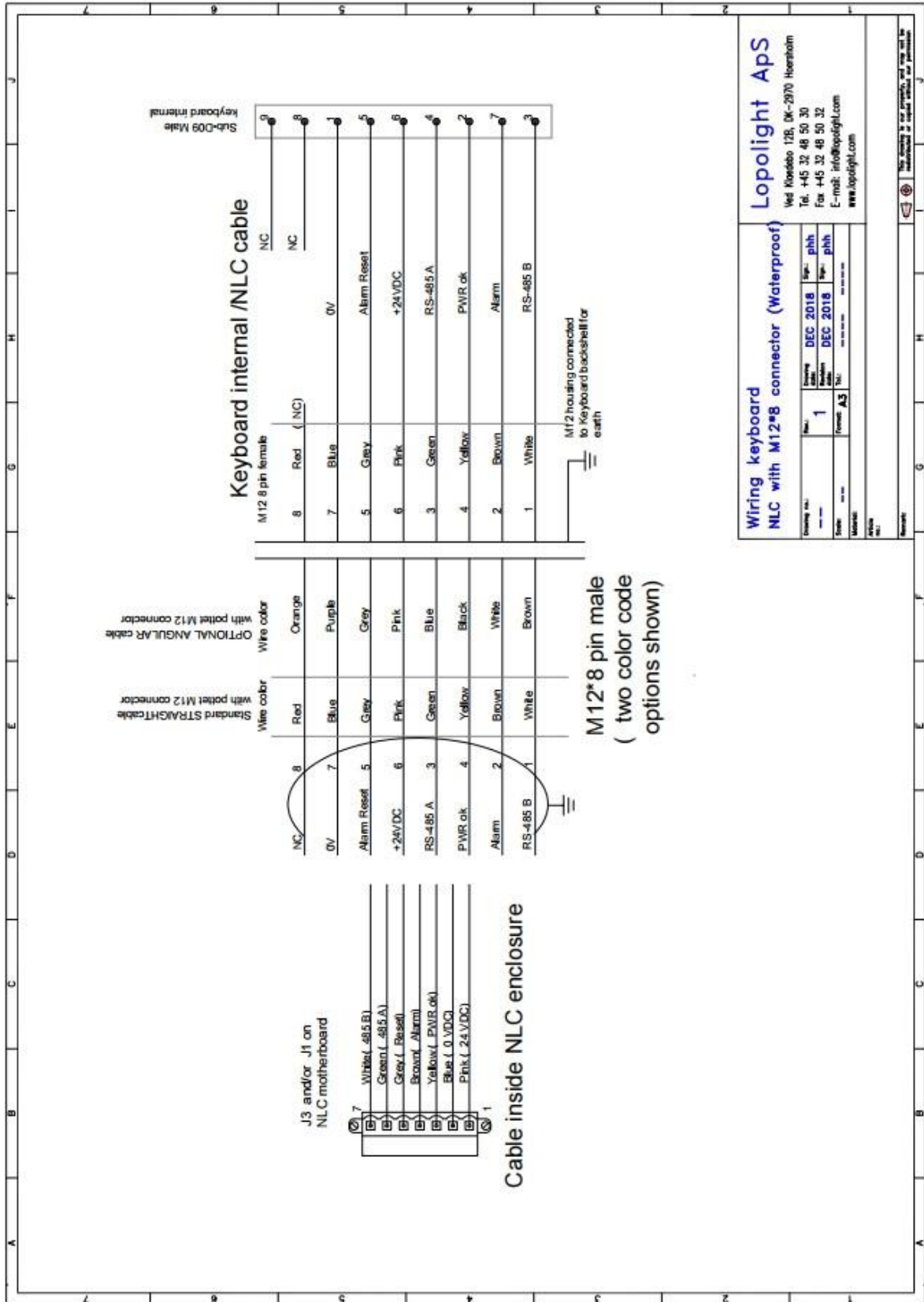

3.5 Controller, service and maintenance

Adjustment of power-supplies: (only applies if redundant power-supply is fitted)

Use a digital multimeter set to DC voltage, measure across any of the positive and negative output terminals on the power supply.

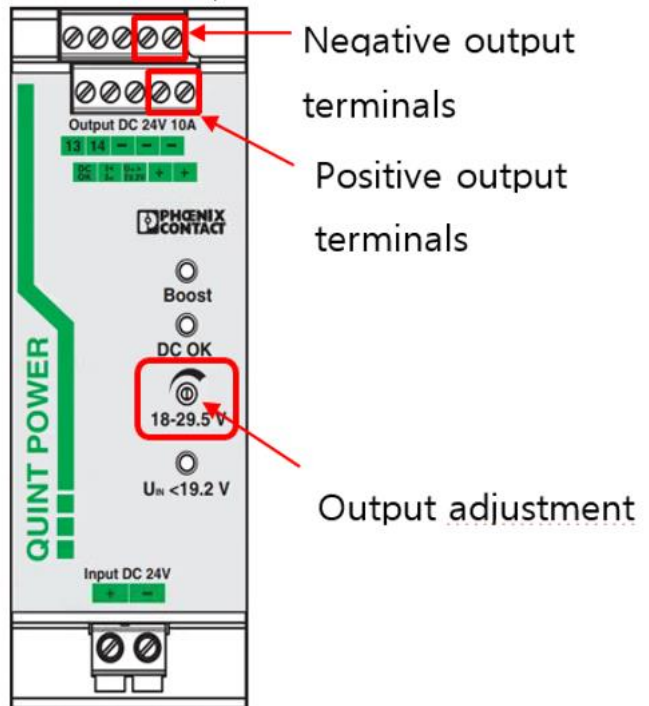

The power supply shown is a DC/DC, however the terminals and adjustment potentiometer is located in the same place on an AC/DC power supply

Adjust the power-supply in accordance with the listed outputs;

- Primary power supply output: 26,5 VDC.
- Secondary power supply output: 24,5 VDC.

*NLC equipped with Ice class function must be set to 28,5/26,5 VDC(Primary/Secondary)

LMR replacement:

Please refer to the “Replacing the LMR instructions on page 25 in this manual.

Other service operations:

The system should not be disassembled in any other way than specifically described in this manual.

For other service operations, please check the website (www.lopolight.com) for instructions, if not found please request the appropriate manual at info@lopolight.com

Failure to comply with this will potentially void warranty.

4.0 Panel, basic data

Size

The control panel comes in three (3) sizes depending on the amount of control buttons required for the individual project.

If the total number exceeds 28, a dual system will be set up and the lights divided amongst them in the most logical way unless otherwise specified.

Panels

- A) 1-14 lights, 205 x 180 x 42.5mm, -panel cut-out: 180 x 155mm
- B) 15-21 lights, 230 x 205 x 42,5mm, -panel cut-out: 205 x 180mm
- C) 22-28 lights, 280 x 205 x 42,5mm, -panel cut-out: 255 x 180mm

Ingress protection:

IP-56 from front but can be upgraded to IP67 if required. Panel must be sealed along the edges towards the waterproof console if installed in a wet environment.

The control panel consists of:

- An aluminium base plate with laser engraved customer specific texts for each button.
- Navigation light control buttons, including dimmable status indicators.
- Four programmable function buttons.
- One control panel indicator dimmer dial.
- One alarm reset button with dimmable alarm status indicator.
- One buzzer for audible alarms.

Power-supply:

The control panel is powered by the NLC via the SUB-D9 male (Com 1).

Interfaces:

COM 1, Male SUB-D9;

Usage: Connection to Navigation light Controller only (RS485, 38400,N,8,1)

Pinout:

- 1: GND
- 2: PWR-ok*
- 3: RS-485 B
- 4: RS-485 A
- 5: Alarm reset**
- 6: +24V
- 7: Alarm***
- 8: NC
- 9: NC

COM 2: Female SUB-D9;
Usage: NMEA-0183 (RS-232, 4800, n,8,1) connection to VDR, AMS and other auxiliary equipment in accordance with IEC-61162.
Pinout.
1: NC
2: NC
3: NC
4: NC
5: GND
6: NC
7: RS232 Rx
8: RS232 Tx
9: NC

- * PWR ok: signal is low when both primary and secondary PSUs are working properly.
- ** Alarm reset: Pull down to system GND to reset audible alarm
- *** Alarm: Signal pulls down to system GND when in alarm state. Max sink: 200mA

Protective ground:

Panel: M3 bolt at rear of panel, marked with earth sign.
Recommended grounding cable dimension: 2.5 mm²

Working principle:

When a button is pressed, it is interpreted and converted into a RS-485 telegram using either the "N" or "P" protocol, and sent on the Com port(s).
The telegram can control 3 Lopolight products:
1: Lopolight NLC (described in this manual)
2: Equipment based on the Lopolight NPC driver (nav. lights with integrated RS-485 com ports. Typically used on navy and SAR vessels)
3: Equipment based on the Lopolight MTG driver (High power LED driver)

4.1 Panel, installation guideline

Make an appropriate rectangular cut-out in the console. Please refer to the cut out dimensions described in 4.0 Panel, basic data, page 13. Cut-out: +/- 2.5mm, de-burr sharp edges.

Position the panel in the cut-out and align as needed.

Mark the four holes for mounting the panel, remove the panel, and drill.

The holes may be threaded to M4, else use appropriate nuts.

Bolts should be DIN 912, as these will seat neatly into the countersink in the panel front.

Protective Ground must be connected to ground-point located at the back of panel. It is recommended to use star washer under a ring terminal to ensure proper ground connection.

Connect the SUB9-D connector of the interconnection cable to the panel and fasten the screws to ensure proper connectivity.

Connect the free end to the NLCs J1 or J3.

Screen must be connected to the GND rail in the NLC.

If two panels are connected, they must be connected to J1 or J3 in the NLC in parallel.

4.2

Type A 1-14 lights

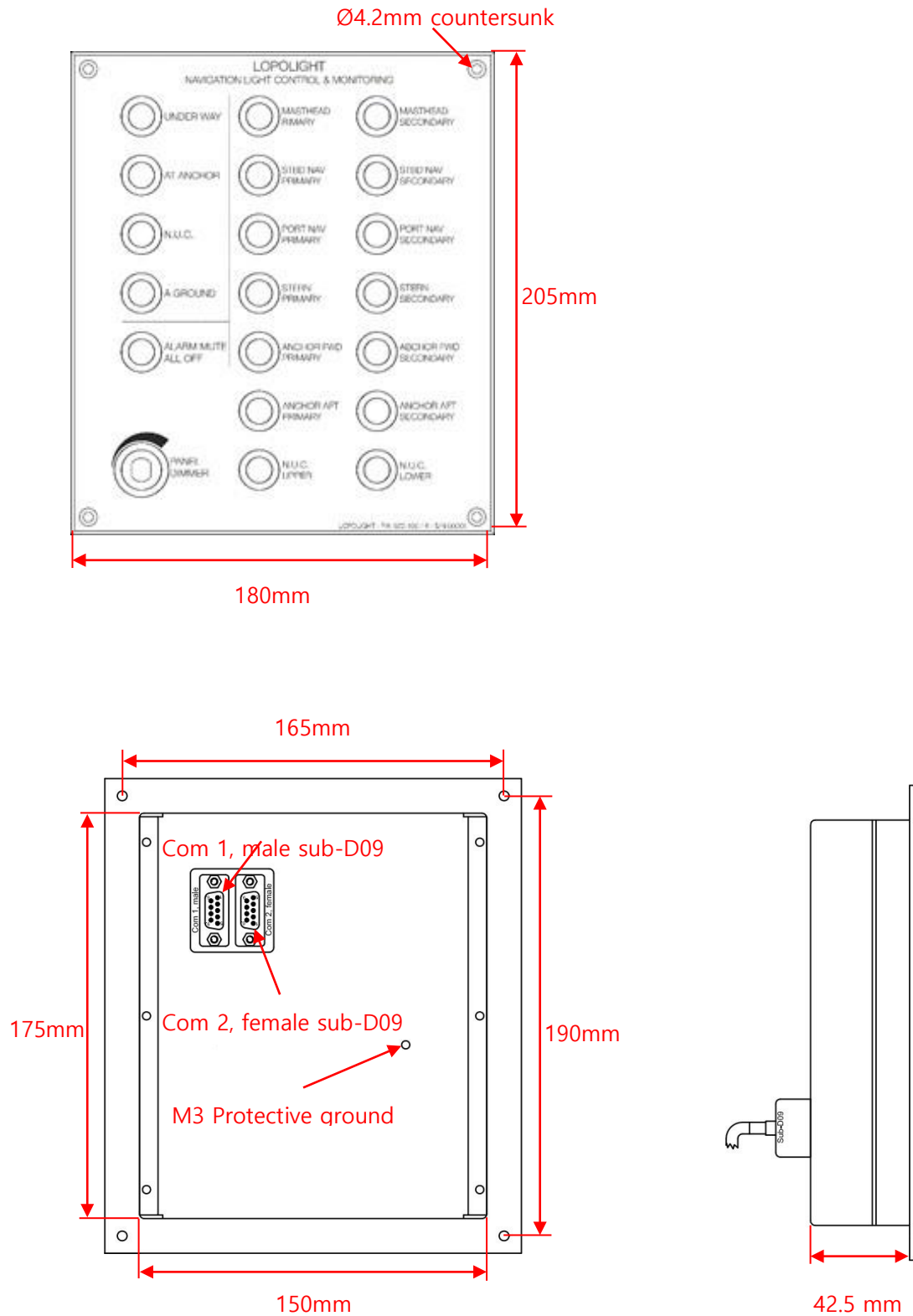

Type B _ 15 - 21 lights

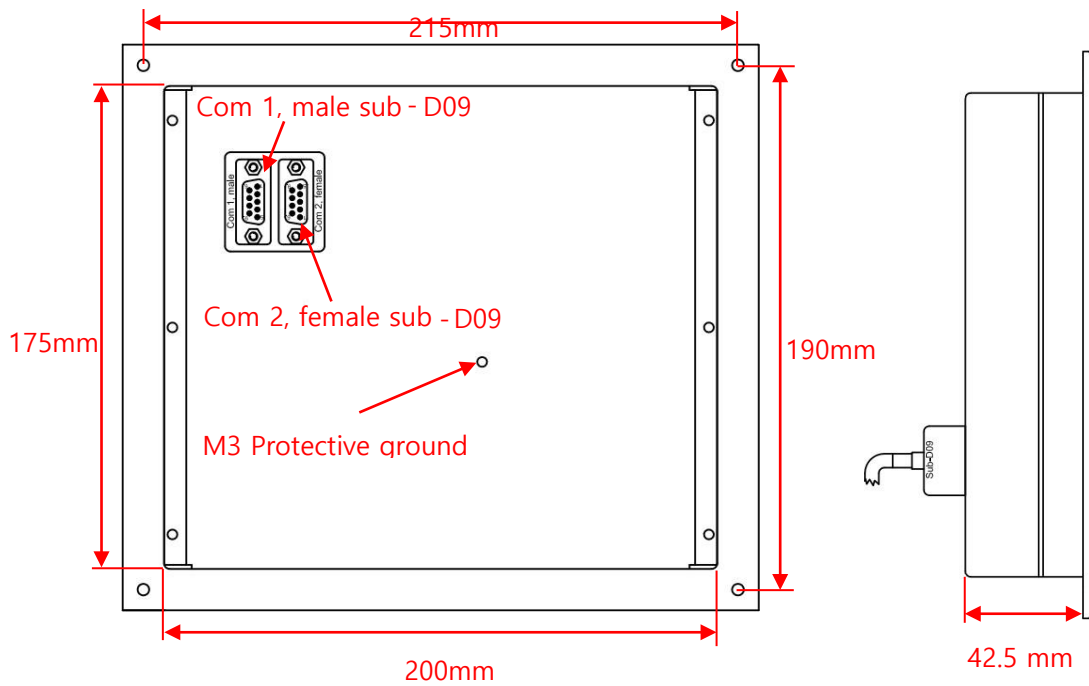
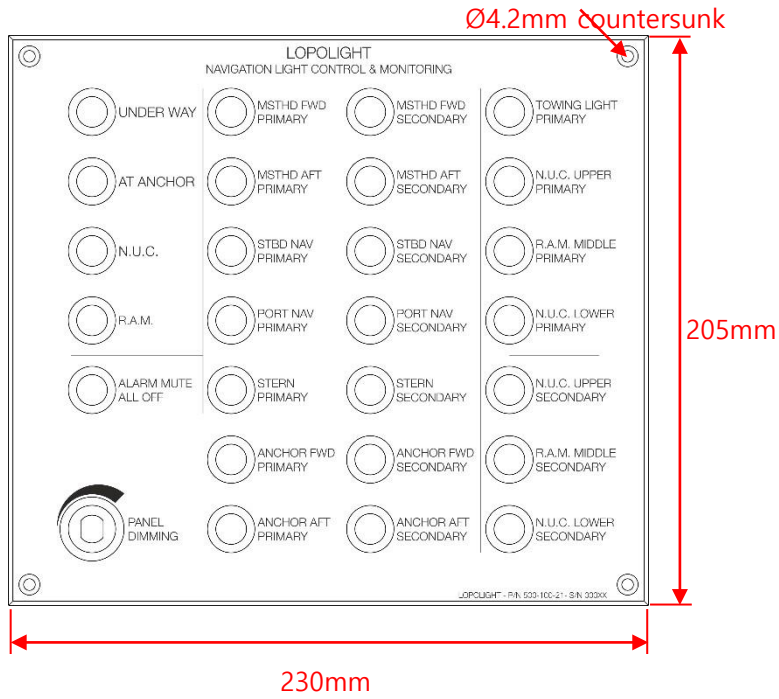

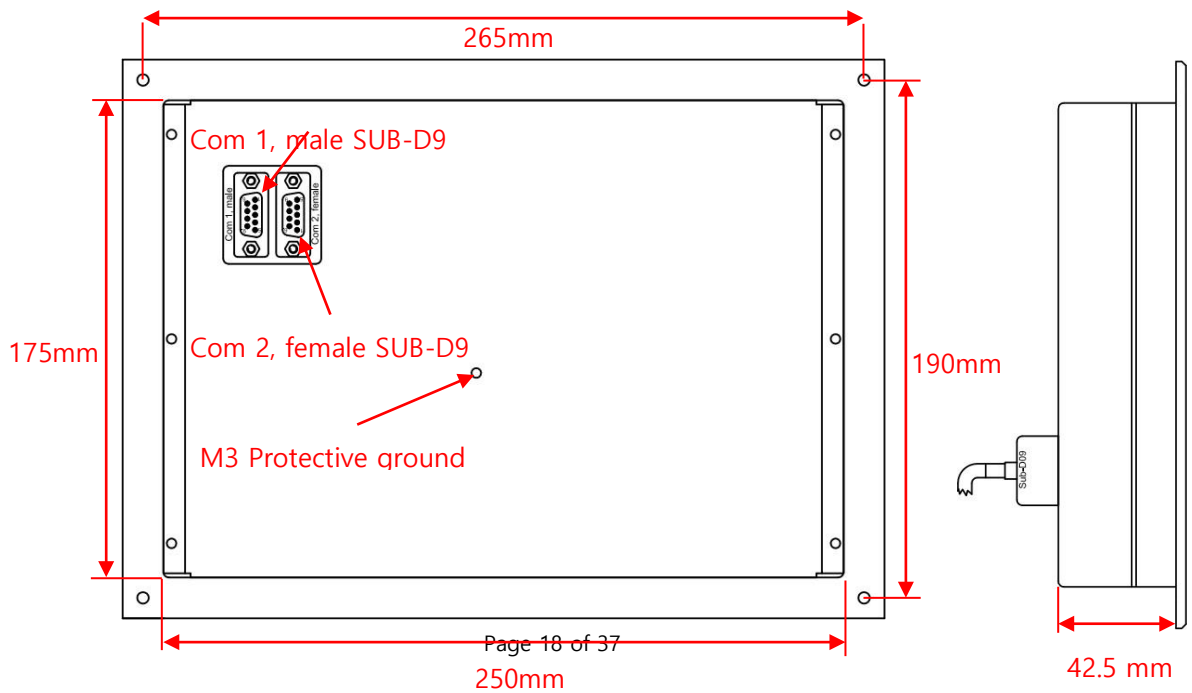
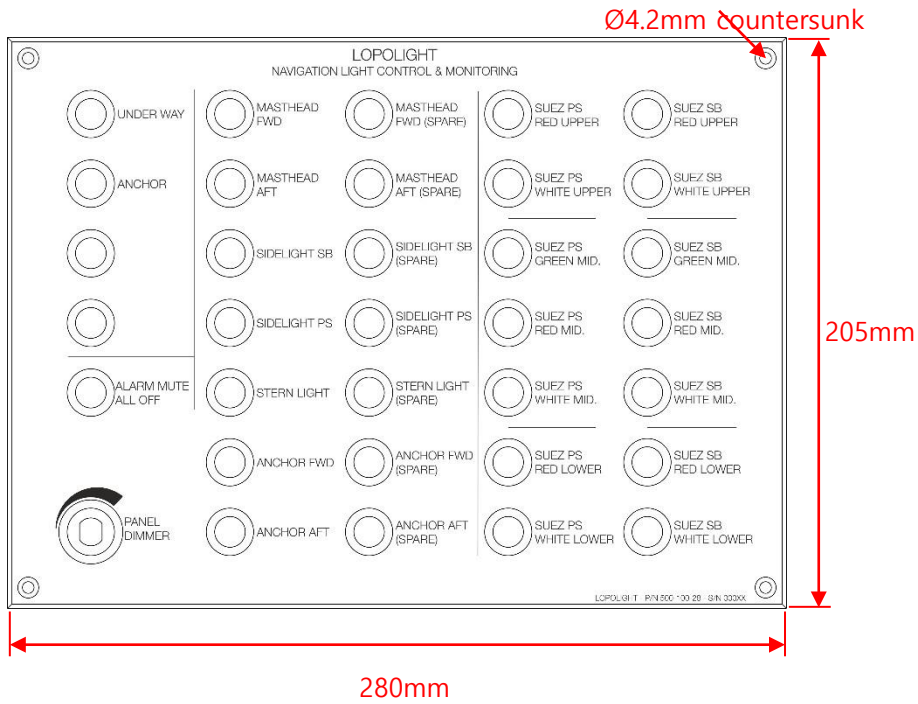

5.0 Initial installation and set-up

Protective ground connections - general guidelines:

The NLC must be connected to ships protective ground (hull) via the external grounding point, marked PE. Use the M6 terminal and appropriate lock washers to ensure good connectivity even under challenging circumstances.

If the feed wires to the individual navigation lights are of a screened type, then the screens must be connected to a PE point. This can be accomplished by using the middle pin on the 3-pin connector(s) for the lights or connecting to a PE point outside of the enclosure. It is permitted not to use un-screened cables the last ~2 meters before the enclosure.

Hardware connections, NLC:

- 1) Make sure the two circuit breakers are open.
- 2) Connect the individual navigation lights to the NLC light terminals located along the right hand and left hand side of the NLC.

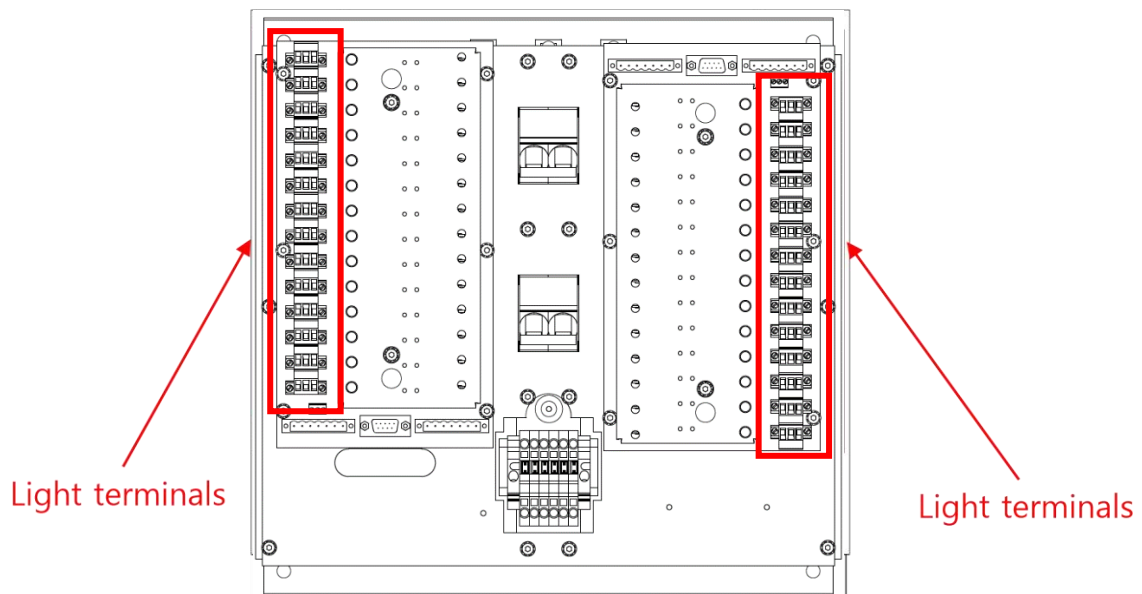

3) Connect primary and secondary power to the NLC.

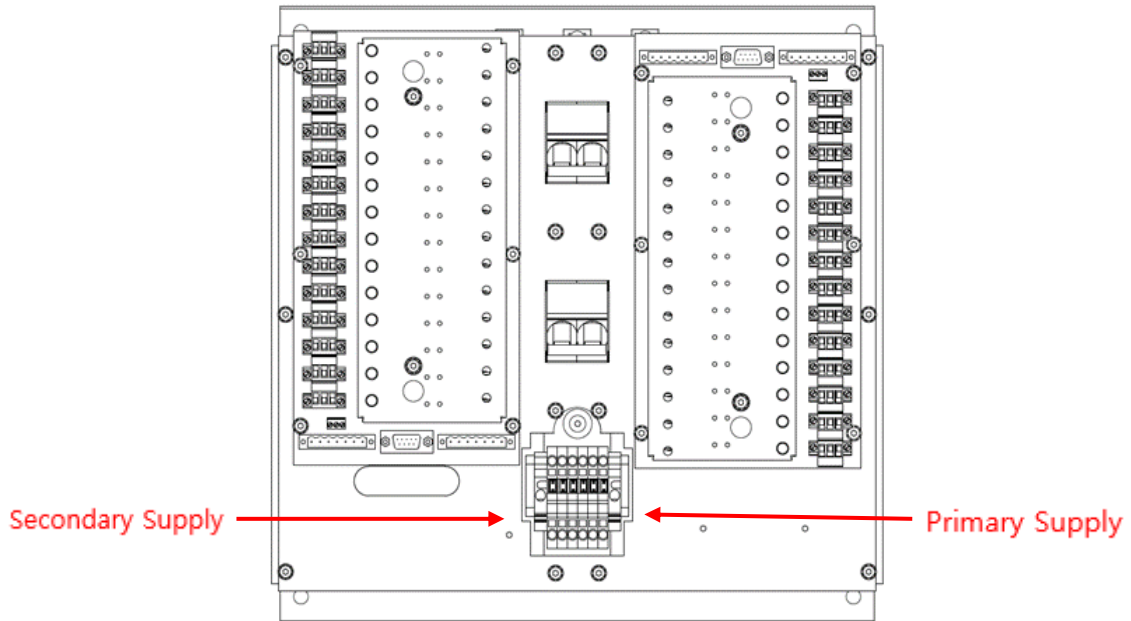

4) Connect the cable from the control panel to either J1 or J2 in the NLC. Lead colours and connections can be seen on the schematics on page 11 in this document.

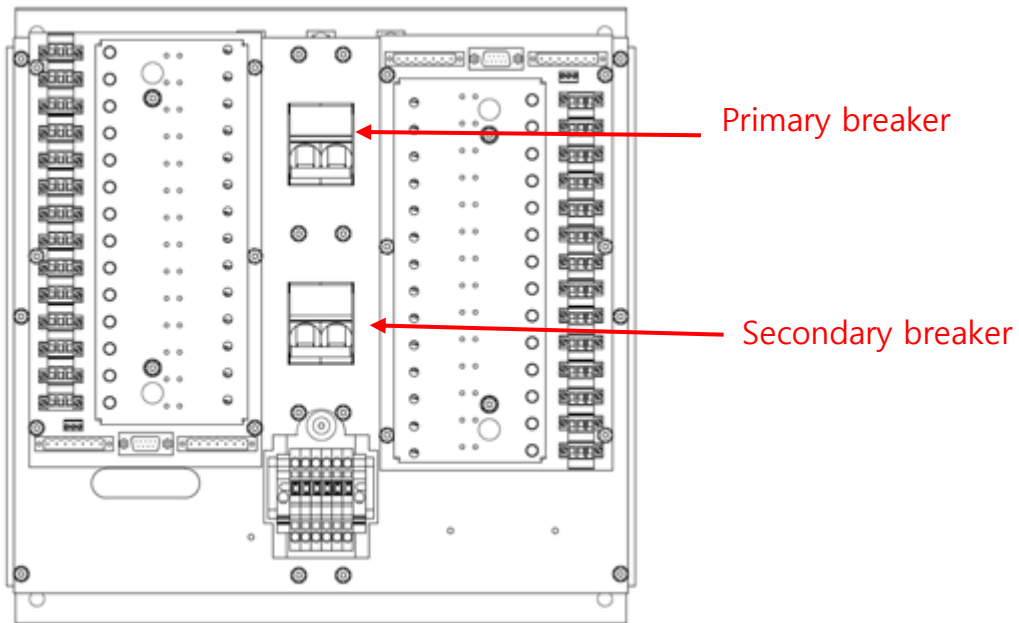

5) Turn on system by closing the circuit-breakers.
(Alarm will sound now. Can be silenced by pressing Alarm reset button on panel)

6) The system is now ready to be set-up.

5.1 Teach-in procedure

Every LMR/Q must learn the individual characteristics of the light connected in order for the monitoring to be accurate and avoiding false alarms.

The Teach-in process makes sure that present consumption (in Watts) is stored in the local memory of the LMR/Q for monitoring purposes.

- 1) Turn off all lights, using the individual control buttons.
- 2) Turn on the light connected to POS1 either using the control panel or the manual/emergency button located on the LMR/Q, after lamp has been detected/startup flash, the alarm will sound and the LMR/Q turns red.
- 3) The LMR/Q is ready 45 sec after the LED turned red/alarm sounds, activate the teach-in switch for POS1. (Insert a 2mm plastic pin or another non-conductive item and pry carefully to activate the switch. During teach-in, the LED on the front of the LMR/Q will flash yellow. (When teach-in is complete, the alarm will turn off and the OK LED appear)
- 4) Please let the process end before moving to the next LMR/Q.

If activating the teach-in button proves troublesome, it may help if the LMR/Q cover is removed to ease the access to the teach-in buttons. During the teach in, a yellow light will flash on the LMR/Q, it turns green when teach in is complete

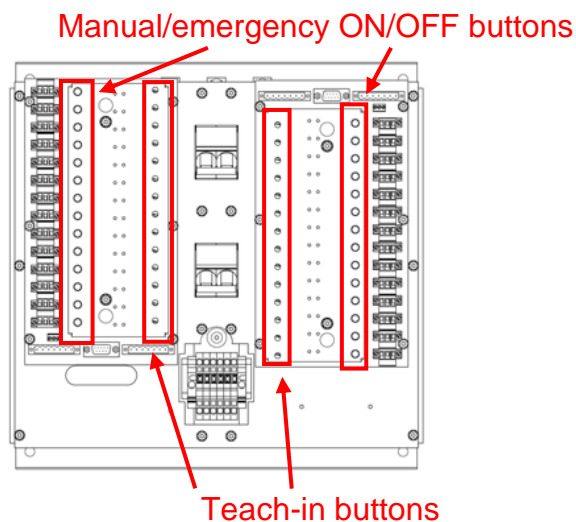

- 5) Turn off the light connected to POS1.
- 6) Repeat step 2 through 5 for all installed positions.

5.2 Programming the panel

The panel can be programmed with various features depending on the needs of the installation.

- a) Panel number: The panel can be programmed as number 1 or 2, this is mostly used in systems containing more than 28 lights and an external control which needs to control the individual lights, or register which light was controlled.
- b) Pairing: Two (2) keys in the panel can be paired in an either-or configuration which is commonly used for primary and secondary lights of the same physical position. When two lights have been paired only one can be switched on at any given time, however if the light being switched on fails, the alternate light will automatically be switched on instead. An alarm will still sound, and a visual indicator will show which light failed.
- c) Grouping: A number of lights can be assigned to a group with a group key being assigned. This feature is normally used to combine different quick sets of lights, for example the masthead, port and starboard sidelights as well as stern light could be switched on at the same time with a group button indicating the vessel is "Under way".
The same feature can be used to show any variety of signals the vessel is capable of, such as "Not under command", "Restricted ability to maneuver", "At anchor", "Fishing", "Trawling" etc. The only limit is the number of lights connected to the NLC (Maximum 28) as the group feature does not work across panels.
- d) Monitoring or relay: The monitoring function in the LMR/Qs can be disabled and enabled using the control panel. This feature is commonly used on strobe lights as the flashing will cause the measured effect used by the light to fluctuate and thus create false alarms in the system.
This is done by turning on the light button, and pressing and holding it for approximately 15 sec.

Panel number configuration procedure:

To configure the panel as #1(Master), press and hold keys 1 through 4 for approximately 20 seconds.

To configure the panel as #2(Slave), press and hold keys 5 through 8 for approximately 20 seconds. This also applies for the rest of the connected slave panels, if there are more than 2 panels.

The panel number can be verified by reading status messages on an external device such as a PC.

All groups and pairing are removed when setting the panel number, these must then be re-applied manually afterwards.

Pairing procedure:

Press the two keys to be paired simultaneously for 10 seconds. They will both light up, and switch off when the pairing is successful.

To de-pair, press two already paired keys simultaneously for 10 seconds.

Grouping procedure:

Turn on the lights that should be grouped.

Press the desired "Group key" and the key marked "Alarm reset / All off" simultaneously for 10 seconds.

To de-group: Activate the group key and press and hold the group key and the key marked “alarm reset / all off” simultaneously for 10 seconds.

Disabling monitoring of a light:

To disable the monitoring of a light, press and hold the button for the light for 15 seconds. To re-enable the monitoring, press and hold the button again for 15 seconds.

The below image shows the keys and their addresses on a 28 key control panel.

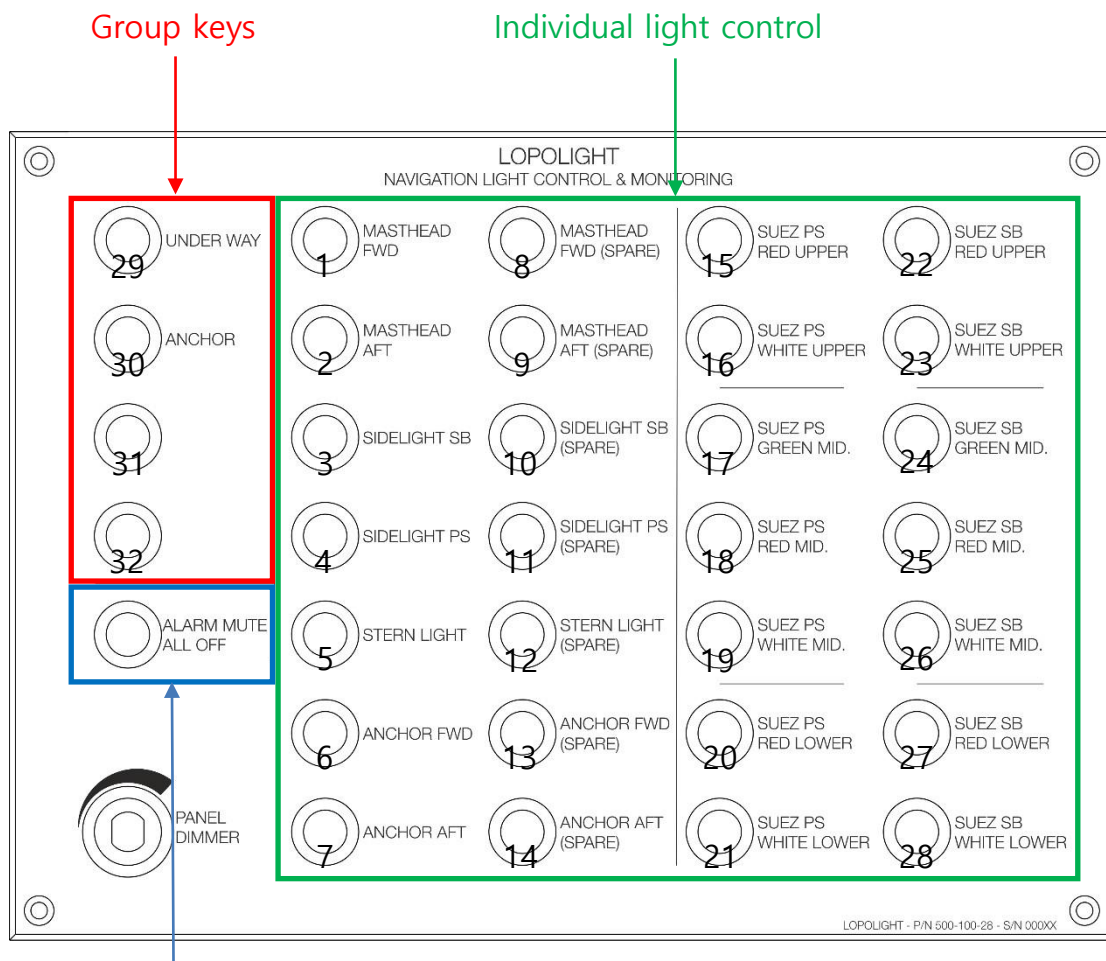

Alarm mute / All off

6.0 Manual control:

Every navigation light is connected to an individual monitoring relay (LMR/Q) in the NLC. Each LMR/Q carries a manual/Emergency control button labelled “ON/OFF”, two status LEDs (Green = ON, red = alarm).

Using the manual/emergency on/off button the lights can be controlled directly from the LMRs, however if a panel is connected and active, the alarm will sound as the command was not sent through the system to operate the light in question. To avoid this, simply disconnect the panel before utilizing manual control.

7.0 System LMR/Q's:

If the system has not been set up from factory, a system reset shall be performed in order to scan for present LMR/Q's.

7.1 System reset

Press and hold key 1, 2, 3 and 4 simultaneously for 20 seconds for panel #1, Key 5, 6, 7 and 8 for panel #2.

When the system reset is performed, all groups and pairings are removed and must be set up manually as described earlier in this manual.

7.2 Setting the address of the LMR/Qs: (with white DIP switches)

Each individual LMR/Q must be assigned an individual address used by the RS-485 network in order to respond to commands sent from either the control panel or an external device.

When a system is delivered from Lopolight, all LMR/Qs has already been set up with their corresponding addresses.

Address 1 through 28 are all legal. Whereas address 0 (zero) is NOT.

Address 29 through 32 are reserved for the group keys, but in special circumstances these can be used for individual lights if LMRs, are installed for this.

The addresses are set using binary logic on the small dip-switch on the LMR/Q.



Bit combination on LMR/Q pictures: $2+4+8=14$

See next page for full table of Bit combinations (1-28).

Position	Bit 1	Bit 2	Bit 3	Bit 4	Bit 5	Bit 6
1	On					
2		On				
3	On	On				
4			On			
5	On		On			
6		On	On			
7	On	On	On			
8				On		
9	On			On		
10		On		On		
11	On	On		On		
12			On	On		
13	On		On	On		
14		On	On	On		
15	On	On	On	On		
16					On	
17	On				On	
18		On			On	
19	On	On			On	
20			On		On	
21	On		On		On	
22		On	On		On	
23	On	On	On		On	
24				On	On	
25	On			On	On	
26		On		On	On	
27	On	On		On	On	
28			On	On	On	

8.0 Test procedure.

- 1, Ensure that all navigation lights are connected, and teach-in has been performed.
- 2, Switch on all individual lights using the keys on the control panel.
- 3, Check that the lights are operating as intended.
- 4, Press All Off for 5 seconds.
- 5, Check that the appropriate lights switch on.
- 6, Switch the group off using the same group button and continue to test each group until all groups has been verified.
- 7, Switch a paired light on and then activate the key for the other part of the pair, the first light should go off and the second light go on.
- 8, Switch a paired light on and then disconnect the light from the terminal in the NLC, the first light should go off and the second light go on and an alarm will sound within 15 seconds as well as a visual indicator showing which light was disconnected
- 9, Perform steps 7 and 8 for all pairs.
- 10, On systems with emergency power supply, disengage the primary circuit-breaker.
- 11, Check that an alarm is given, and all navigation lights still are active.
- 12, Engage primary circuit-breaker again.
- 13, On systems with emergency power supply, disengage the secondary circuit-breaker.
- 14, Check that an alarm is given, and all navigation lights still are active.
- 15, Engage secondary circuit-breaker again.
- 16, Press All Off for 5 seconds.
- 17, Switch the individual lights on using the manual/emergency on/off button located at the LMR/Qs, verify that the lights are switched on. An alarm will sound every time a light is switched on.
- 18, Switch the individual lights off using the manual/emergency on/off button located on the LMR/Qs, verify that the lights switch off.

If any of the above listed checks fail, contact relevant technical support.

9.0 Using the panel

Navigation light control panel User manual

Panel dimming: The indicators on the panel can be dimmed from 0 to 100% using the dimmer in the lower left corner of the panel. Make sure the dimming is NOT set to absolute 0 when operating the panel as this will make it too difficult to see changes in status.

Individual keys: Press to switch a light ON. Press again to switch it OFF. The light connected is active when the indicator shows a green light.

Group keys: Press the key that corresponds to the ships situation. If any navigation light in the given group is detected faulty, then the group indicator will not be lit, and alarm given. IF a faulty navigation light is paired with a secondary navigation light, and this is activated automatically by the panel, the group indicator will remain lit. An alarm will still be given to draw attention to the defective light.

All Off / Alarm reset key:

Primary function: Press and hold this key for 5 seconds to turn all active navigation lights off.

Secondary function: Activate this key briefly to silence the acoustic alarm signal. The alarm condition will remain active but the alarm indicator will change from flashing to steady light.

Alarms: The system responds with an alarm in the following cases;

- a) Faulty navigation light: The corresponding key and alarm reset key will flash.
- b) Faulty primary or secondary power-supply: The Alarm reset key will flash, individual indicators will remain active.
- c) No data-communication between panel and NLC: The alarm reset key will quick flash.

Action in case of alarm:

Please note that these are guidelines only, and **DO NOT** have priority over ships procedures.

Alarm case a): Activate secondary navigation light if present.

(May already have happened automatically). **Notify technical officer.**

Alarm case b): **Notify technical officer.**

Alarm case c): Navigation lights can be controlled manually directly from the NLC.

Notify technical officer – The panel may be disconnected when controlled manually to avoid further alarms during manual operation.

9.1 Spare parts:

Lopolight P/N: Name:

400-018/Q	LMR/Q
600-917	115/240 VAC power-supply
600-918	24/24 VDC power-supply
600-944	Sub-D panel/NLC connection cable, 10 meters
601-927	Circuit-breaker (10A) for 24VDC
601-928	Circuit-breaker (6A) for 115/240VDC
600-668	3-pin plug for navigation light connection in NLC
900-733	Ground strap for NLC enclosure (15 cm mesh)

10.0 Troubleshooting guide and instructions Alarms and error indications on control panel.

Line:	Error indication:	Possible reason	Fault finding action: Check if OK	Action if NOT ok	Reference in manual:
1	Audible alarm + Red button blinking (NO individual indicator active) (1)	Primary <u>or</u> secondary NLC P-S failing	Check P-S AC input Check P-S DC out on both "Phoenix" P-S in NLC	Change faulty P-S	Section 12.0 P31
2	Audible alarm + Red button blinking (NO individual indicator active) (2)	One of the two NLC circuit breakers in off-state	Re-engage NLC circuit breaker	See line 1	Section 6.2 P20
3	Audible alarm + Red indicator blinking + Green indicator blinking (1)	Failing Navigation Light	Navigation light connection/function	Provide light with 24VDC and check for function	Section 15.1 P45
4	Audible alarm + Red alarm indicator blinking AND Green individual indicator blinking (2)	Failing LMR	Replace LMR (Remember dip-sw. settings AND teach-in procedure)	--	Section 13.0 P34
5	Audible alarm + Red alarm indicator blinking AND Green individual indicator blinking (3)	Hoistable or portable light(s) not connected (Deck-level)	Check light in question is connected	Go to line 3	
6	Red indicator blinking quick	No data communication to NLC	Check connectors. Specifically check 7-pin (J3) connector in NLC is in place. (may have been disconnected for fault finding)	Check if one LMR is causing trouble by removing one by one. Replace faulty LMR	Section 13.0 P34

7	(Left blank)				
8	No indicators illuminate (1)	Dimmer set to Zero	Turn dimmer dial full clockwise	Replace microprocessor	Section 14.0 P38
				board in panel	
9	No indicators illuminate (2)	No power to panel	Specifically check 7-pin (J1) connector in NLC is in place. (may have been disconnected for fault finding)	Check 24V present in M12 connector at back of panel	Section 4.1 P15
10	Light does not come on AND no indications on LMR	No LMR set to corresponding address	Address setting on relevant LMR	Set address correctly (dipswitch on LMR)	Section 9.3 P25
11	Alarm on panel – after 1-5 minutes <u>and</u> two navigation lights come on at the same time when pressing only one “Individual control button”	Two LMR share same address	Address setting on relevant LMR	Set address (dipswitch on LMR) correctly – no two equal addresses are allowed	Section 9.3 P25

Error indications on LMR (in NLC)

Situation: (one) navigation light supposed to be on – activated either from panel or manual/emergency switch

Line:	Error indication:	Possible reason	Fault finding action: Check if OK	Action if NOT ok	Reference in manual:
1	Green OK indicator not active	Navigation light faulty	Navigation light illuminates	Check if navigation light works	Section 15.1 P45
2	Red alarm indicator illuminated (1)	Missing "Teach-in"	Perform Teach-in	Line 3	Section 6.3 P20
3	Red alarm indicator illuminated (1)	Navigation light faulty	Navigation light connection/function	Change navigation light if proven faulty	Section 15.1 P45
4	Center indicator orange (1)	Short circuit in cable to navigation light (Current limiter is in function)	Check cabling/connections/connectors	Go to line 5	
5	Center indicator orange (2)	Short circuit in navigation light (Current limiter is in function)	Navigation light connection/function	Change navigation light if proven faulty	Section 15.1 P45
6	Center indicator is blinking orange after pressing teach-in button	Teach-in procedure running (some 5 seconds)	No action. Not an error	--	--
7	Center indicator is <u>NOT</u> blinking orange after pressing teachin button (1)	Navigation light not connected to output terminals (or not using any current)	Navigation light connection/function	Check functionality of navigation light	Section 15.1 P45
8	Center indicator is <u>NOT</u> blinking orange after pressing teachin button (2)	LMR faulty	Replace LMR (Remember dip-sw. settings AND teach-in procedure)	--	Section 13.0 P34

9	Alarm on panel. Navigation light not on. LMR: Center indicator blinking green AND no indications on Green/red front	Navigation light activated on panel – but switched off at manual/emergency button on LMR	Switch on at LMR (press manual/emergency button once)	--	Section 8.0 P23
	indicators.				
10	Center indicator constant red	Navigation light failure	Navigation light connection/function	Change navigation light if proven faulty	Section 15.1 P45
11	Center indicator blinking green slowly AND front indicator constant green	Navigation light will expire within 2000 hours	Change navigation light when convenient	--	--
12	Center indicator alternating red/green AND front indicator constant red	Navigation light has expired it 50.000 hour lifetime	Change navigation light as soon as possible.	--	--

10.1 General test of Navigation light function

Case one: Light still mounted on hull:

Open NLC enclosure and identify the connections for the light to test.

1. Disconnect relevant green 3-pin connector in NLC (marked: "POS-XX")
2. Connect plus and minus to 24VDC source and check navigation light for correct function (illuminates when supplied with 24VDC, nominal).

Case two: Light unit has been dismantled from (K-Lock) base and in workshop:

1. Connect test cable to navigation light connector
2. Apply 24VDC to relevant leads. Check light for correct function (illuminates when supplied with 24VDC, nominal).
3. If light(s) does not seem to function correctly, change unit to new. Note serial number of light for reporting to manufacturer.

Tip: It may be a good idea to disconnect panel connection cable from J1 in NLC before working on the individual lights, as undesired alarms are likely to appear on the panel. 24VDC for test is available on J1 pin1. 0V on pin 2. (J1 is free if the panel is disconnected)

Recommended hand tools:

4mm normal flat-tipped screwdriver

Hex keys: 2½, 3, 4, 5mm

PZ2 (star) screwdriver

Multimeter

Test cable that fits navigation light connectors

7 pin connector (female with screw terminals) for J1

11.0 Exploded Illustration of NLC components

Overleaf please see exploded view of the Control Panel, the NLC box, and a detailed view of the box with the monitoring relay.

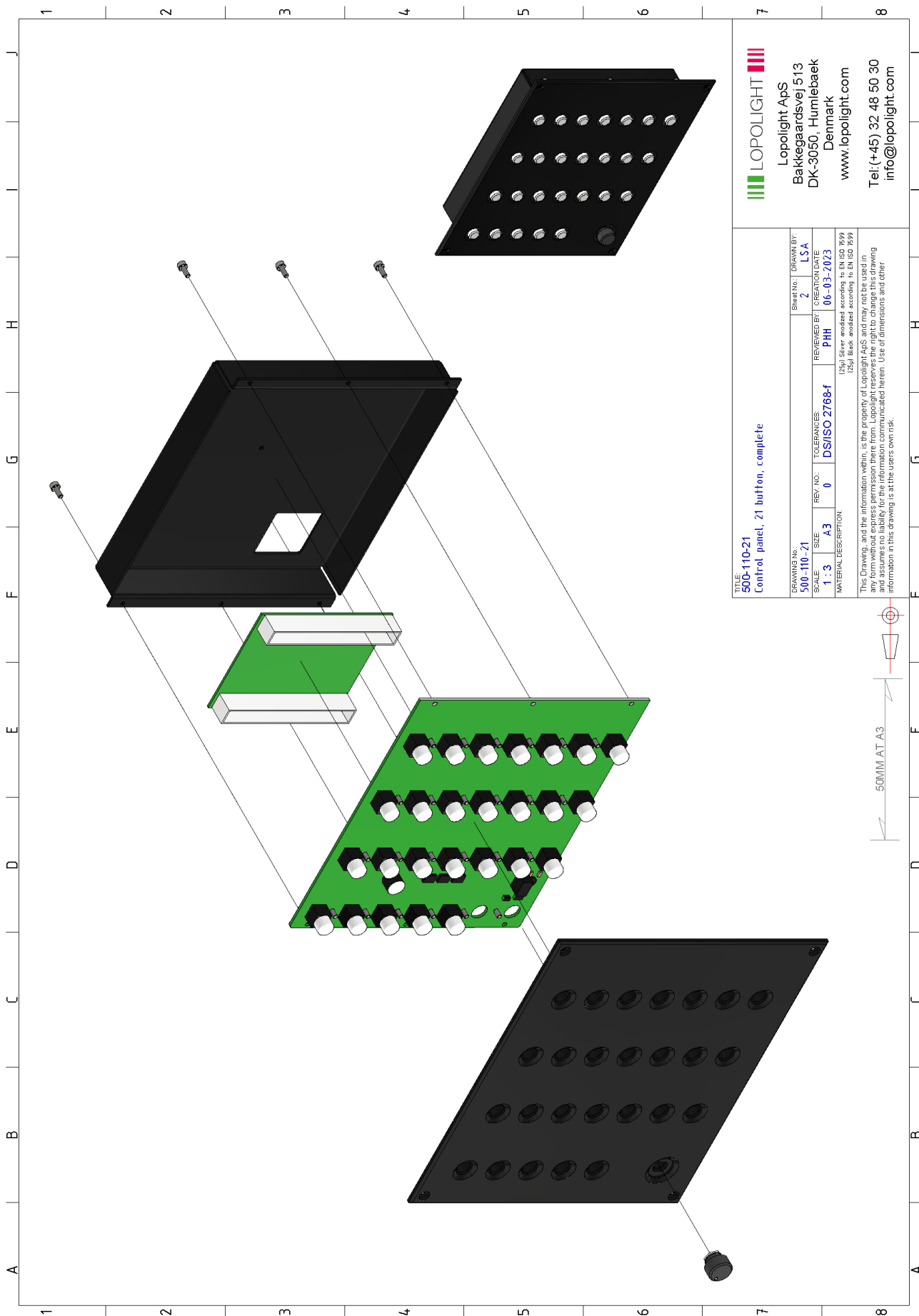

LOPOLIGHT
 Lopolight ApS
 Bakkegaardsvej 513
 DK-3050, Humlebaek
 Denmark
 www.lopolight.com
 Tel: (+45) 32 48 50 30
 info@lopolight.com

TITLE
 500-110-21
 Control panel, 21 button, complete

DRAWING No.	500-110-21	Sheet No.	2	DRAWN BY:	LSA
SCALE	1:3	REV. NO.	0	CREATION DATE	06-03-2023
SIZE	A3	TOLERANCES	DS/ISO 2768-t	REVIEWED BY:	PHH
MATERIAL DESCRIPTION:					
(25μ) Silver anodized according to EN ISO 7599					
(25μ) Black anodized according to EN ISO 7599					

This Drawing, and the information within, is the property of Lopolight ApS and may not be used in any form without express permission there from. Lopolight reserves the right to change this drawing and its associated information without prior notification. Use of dimensions and other information in this drawing is at the users own risk.



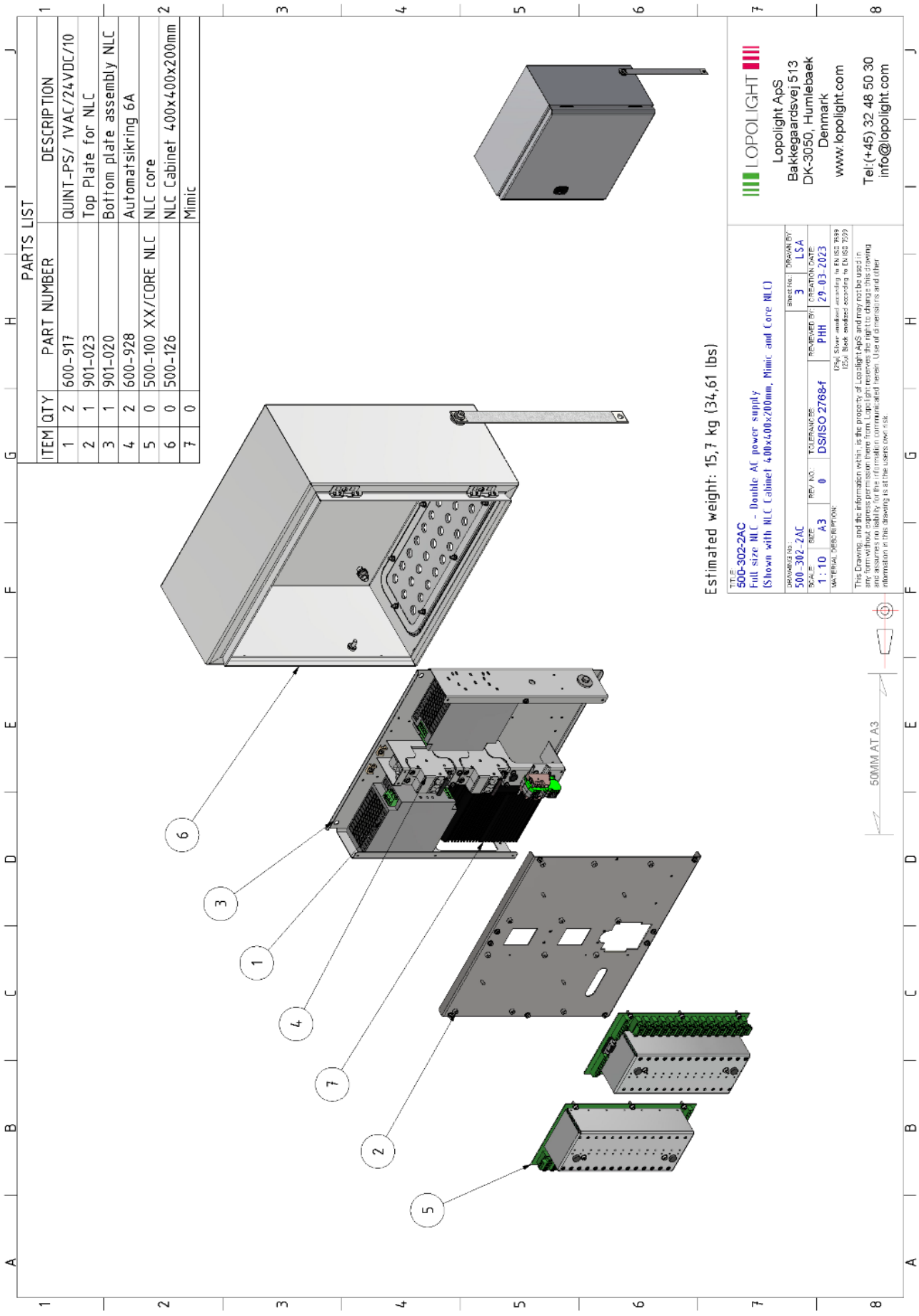

PARTS LIST		
ITEM QTY	PART NUMBER	DESCRIPTION
1	600-917	QUINT-PS/ 1VAC/24VDC/10
2	901-023	Top Plate for NLC
3	901-020	Bottom plate assembly NLC
4	600-928	Automatisering 6A
5	500-100 XX/CORE NLC	NLC core
6	500-126	NLC Cabinet 400x400x200mm
7	0	Mimic

Estimated weight: 15,7 kg (34,61 lbs)

DRAWING NO.: 500-302-ZAC		SHEET NO.: 3		DRAWN BY: LSA	
SCALE: 1:10	REV. NO.: 0	TOLERANCE: DS/ISO 2768-f	REVIEWED BY: PHH	OPERATION DATE: 29-03-2023	
MATERIAL DESCRIPTION: 15% Silver plated according to EN 602 759 12% Black anodized according to EN 602 729					

This Drawing and the information within it is the property of Loplight ApS and may not be used in any form without express permission there from. Loplight reserves the right to change this drawing and assumes no liability for the information communicated herein. Use of materials and other information in this drawing is at the users' own risk.

Loplight ApS
 Bakkegaardsvvej 513
 DK-3050, Humlebæk
 Denmark
 www.lopolight.com
 Tel (+45) 32 48 50 30
 info@lopolight.com

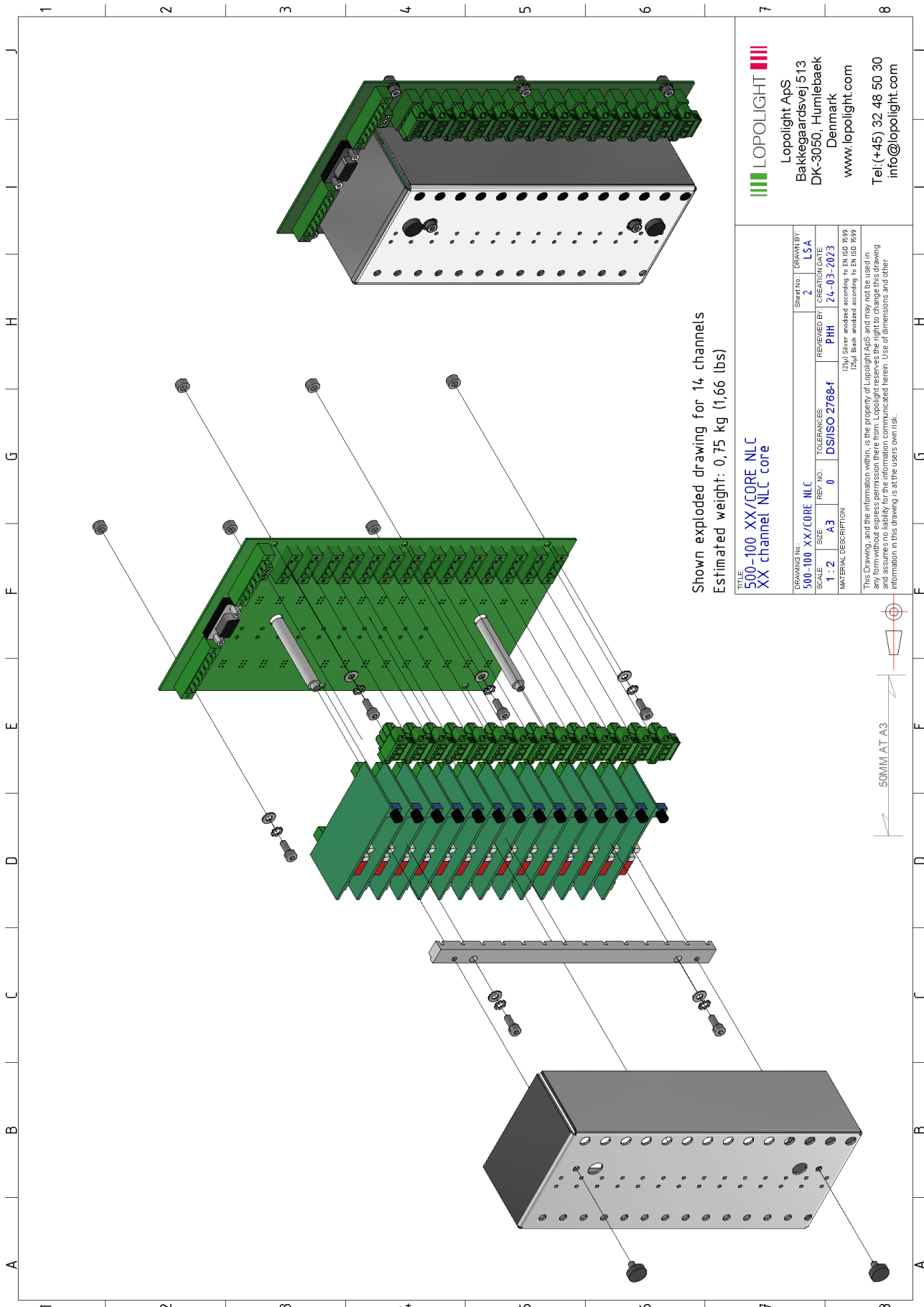

Shown exploded drawing for 14 channels
 Estimated weight: 0,75 kg (1,66 lbs)

LOPOLIGHT

Lopolight ApS
 Bakkegaardsvej 513
 DK-3050, Humlebaek
 Denmark
 www.lopolight.com
 Tel (+45) 32 48 50 30
 info@lopolight.com

DRAWING No.:	500-100 XX/CORE NLC	SHEET No.:	2	DRAWN BY:	LSA
SCALE:	1 : 2	REV. NO.:	0	REVIEWED BY:	PHH
TOLERANCES:	DS/ISO 2768-f	CREATION DATE:	24-03-2023		
MATERIAL DESCRIPTION: (2x) Silver anodized according to EN ISO 7599 (2x) Black anodized according to EN ISO 7599					

TITLE
 500-100 XX/CORE NLC
 XX channel NLC core

This Drawing, and the information within, is the property of Lopolight ApS and may not be used in any form without express permission therefrom. Lopolight reserves the right to change this drawing without notice. All dimensions and tolerances are as specified in the drawing. Use of dimensions and other information in this drawing is at the user's own risk.

Lopolight contact information.

Corporate office

Lopolight ApS
Info@lopolight.com
Phone: +45 32 48 50 30

Holland & Benelux

Melle Klazinga
Melle@lopolight.com
Phone: +31(0)651302298

Northern Europe

Sales manager
Mike Booth
Mike@lopolight.com
Phone: +44 131 285 3307

Regional sales manager

Russ Patton
Russ@lopolight.com
Phone: +1 715 923 1076

Southern Europe

Sales manager
Marco Ravaioli
Marco@lopolight.com
Phone: +39 370 3424391

France & Spain

Maëlle Montel
Sales-france@lopolight.com
Phone: +33 2 90 38 08 81

North America

Sales manager
David Hellar
David@lopolight.com
Phone: +1 215 847 5165